

# ZESTO

## Gas Conveyor Oven CG2416 & CG2418

**Model CG2416**

**16" (40cm) Wide Belt**

**Model CG2418**

**18" (46cm) Wide Belt**



"U.S." Patent # 5,584,237

**40,000 BTU'S**

**cooking temperature up to 600 F° (315 C°)**

**Available in Natural or Propane Gas**



- \* *Stainless Steel Construction.*
- \* *Front mount controls for easy view and access.*
- \* *Electronic temperature control with digital read-out.*
- \* *Variable digital speed control on conveyor belt.*
- \* *Cook time from 1 - 20 minutes.*
- \* *Reversible conveyor belt direction.*
- \* *Thermally insulated for energy efficiency.*

- \* *High velocity precision targeted air flow distribution panels for consistent repeatable baking results.*
- \* *Stackable (up to 3 units high).*
- \* *Super efficient gas burner.*
- \* *Removable front panel, crumb tray, top and bottom air flow distribution panels for easy cleaning.*
- \* *4" adjustable stainless steel legs.*

**Optional s/s stand 24" high  
with locking casters & bottom shelf available**



**Removable panels for easy cleaning**  
"U.S." Patent # 6,192,877 B1

**Ideal for a variety of cooking applications including pizza, seafood, omelettes and other egg dishes, pre-cooked meats, cookies, bakery products, pita breads, heating plated Mexican food and hot submarine sandwiches.**

# Gas Conveyor Oven CG2416 & CG2418



Conforms to: ANSI / UL Std. 197  
Conforms to: CSA C22.2 Std. 109

Conforms to:  
Std. NSF-4

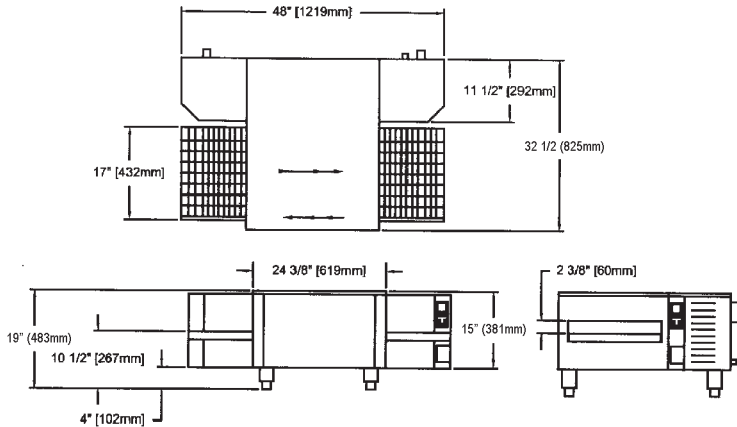

## Model CG2416 (16" belt)

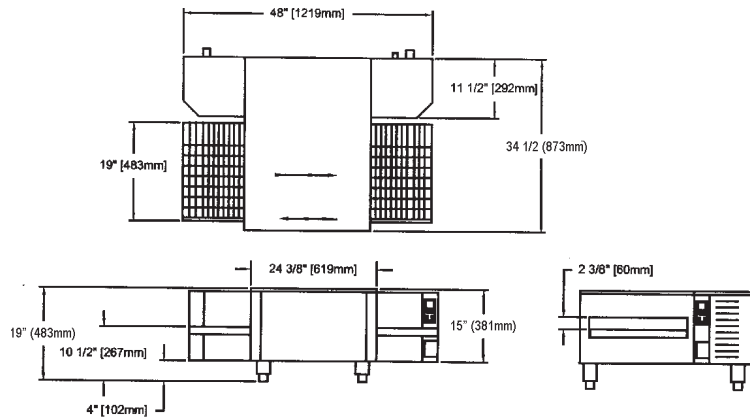
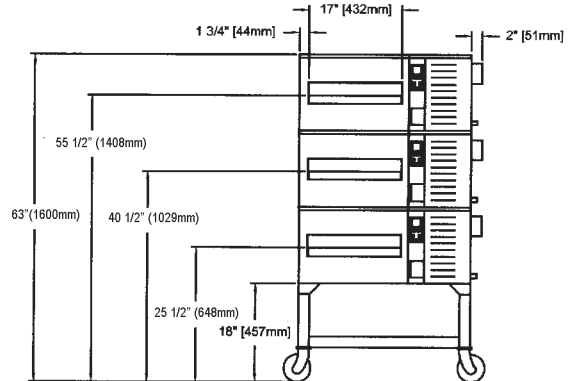

## Model CG2418 (18" belt)

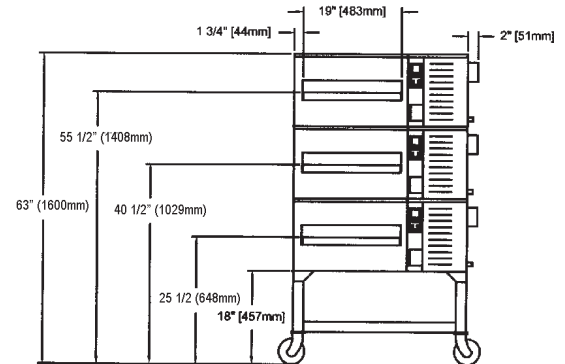

### APROX. PRODUCTION PER HOUR / PER SECTION / BAKE TIME IN MINUTES

Pan diameter	CG2416 (16" wide belt with 17" opening)							CG2418 (18" wide belt with 19" opening)						
	5 min.	6 min.	6.45 min.	7 min.	7.5 min.	8 min.	9 min.	5 min.	6 min.	6.45 min.	7 min.	7.5 min.	8 min.	9 min.
6" (15 cm)	96	80	74	69	64	60	53	144	120	112	103	96	90	80
8" (20 cm)	72	60	56	51	48	45	40	72	60	56	51	48	45	40
9" (22.8 cm)	32	27	25	23	21	20	18	64	53	50	46	43	40	36
12" (30 cm)	24	20	19	17	16	15	13	24	20	19	17	16	15	13
14" (35 cm)	21	17	16	15	14	13	11	21	17	16	15	14	13	11
16" (40 cm)	18	15	14	13	12	11	10	18	15	14	13	12	11	10

Model	Gas Burner	Exterior dimensions	Length of belt	Voltages / Amps	Weight
CG 2416	40,000 BTU'S	48"L x 31"D 122cm x 80cm	48"L x 16"D 122cm x 40cm	110 volts / 1ph / 7 amps 208 / 220 volts / 1ph / 3.5 amps	350 lbs 159 kg
CG 2418	40,000 BTU'S	48"L x 33"D 122cm x 85cm	48"L x 18"D 122cm x 46cm	110 volts / 1ph / 7 amps 208 / 220 volts / 1ph / 3.5 amps	385 lbs 175 kg

Available in 50 or 60 cycles. Amperage could vary if input volts are not the same as indicated.

**ZESTO** FOOD EQUIPMENT MANUFACTURING INC.  
MANUFACTURIER D'EQUIPEMENT EN ALIMENTATION INC.

6450 HUTCHISON, MONTREAL, QC, CANADA H2V 4C8  
TEL(514)278-4621 FAX(514)278-4622  
e-mail info@zesto.ca www.zesto.ca

SPECIFICATIONS SUBJECT TO CHANGE WITHOUT NOTICE.

LES SPÉCIFICATIONS SONT SUJETS À CHANGEMENT SANS AVIS.